



## INSTRUCTION MANUAL





## INDEX

INTRODUCTION .....	page 4
USE .....	page 4
1. INSTRUCTIONS OF USE.....	page 5
1.1 Packaging and Transport .....	page 5
1.2 Preliminary Operations for correct Commissioning .....	page 5
1.3 Adjustments for the first Commissioning and/or subsequent adjustments.....	page 7
1.4 How to use it .....	page 15
1.5 Recommendations for Use .....	page 19
2. GENERAL WARNINGS .....	page 19
2.a Warnings for the Professional User .....	page 20
2.b Warnings for the End User .....	page 20
3. NEGATIVE ADVERSE EFFECTS .....	page 21
4. RESTRICTIONS OF USE .....	page 21
5. STANDARD MAINTENANCE .....	page 22
6. ADAPTATIONS WITH STRUCTURAL CHANGES AND/OR SPECIAL MAINTENANCE .....	page 22
7. PERFORMANCE AND DURABILITY .....	page 22
8. WARRANTY .....	page 23
9. POST-MARKET SURVEILLANCE AND POSSIBLE INCIDENTS .....	page 23
10. DISPOSAL/RECYCLING .....	page 24
11. LABELING.....	page 24
ANNEXES:	page 25
- > Annex A: Technical features	
- > Annex 1: Warranty replacement of components/ Adaptations with structural changes and/or Special Maintenance	
- > Annex 2: Report of after-sales incidents	

**NOTE:** The illustrations in the following Instruction Manual may differ from reality; however, the methods of use and operation remain valid at all times. All technical data in this manual are approximate and do not constitute specifications.

## INTRODUCTION

Dear User, thank you for choosing highly performing PRO MEDICARE medical device.

ADACTA GIÒ is the Frame for Positioning System for children and teenagers, it is the combination of technology and experience in the development of Positioning Systems for users with limited ability. Thanks to its modularity and different possibilities of adjustment, ADACTA GIÒ allows effective adaptation to changes of the user's needs, providing the best comfort with maximum functionality.

As manufacturer, PRO MEDICARE declares that the medical device complies with Regulation (EU) 2017/745.

Pro Medicare's Quality Management System is certified according to UNI EN ISO 9001 and UNI EN ISO 13485 standards.

This manual, drawn up on the basis of the requirements of Regulation (EU) 2017/745 on medical devices, is an indispensable tool for learning how to use the Device safely.

This manual contains all instructions for a correct and safe use of the frame combined with the positioning system.

To this end, it is important to read the information about how to use it carefully, with the express invitation to follow the prescribed indications.

As a manufacturer, Pro Medicare refers to the Professional User as the suitably qualified person (authorised dealer, orthopaedic technician, occupational therapist, healthcare professional, etc.), and to the End User as the person who is intended to use the Device (caregivers, family members, etc.).



*The first commissioning, subsequent adjustments and Special Maintenance must exclusively be performed by the Professional User.*

The Technical features of the device are reported in the Annex A "Technical Features".

After consulting this manual, for further information, please contact the Technical Sales Department at the following number:

**+39 0831 777840**

Monday to Friday from 9 a.m. to 1 p.m. and from 2.30 p.m. to 6.30 p.m.

In case of emergencies outside the working hours, please send a fax to the following number:

**+39 0831 730739**

Or send an email to: [sales@promedicare.it](mailto:sales@promedicare.it)

We will call you back as soon as possible.

In order to ensure appropriate After-Sale Monitoring of Devices placed on the market and put into service, or in the event of an incident during the use, please refer to the instructions stated in the relevant chapter.

## USE

The ADACTA GIÒ Paediatric Frame for Positioning System is made in satin aluminium alloy to ensure lightness and long-lasting durability during the use.

It has been designed and manufactured in compliance with the safety standards of Regulation (EU) 2017/745.

The ADACTA GIÒ frame, due to its modularity, provides multiple configurations able to follow the evolutions of the pathological scheme of the users as well as the growth and the postural changes. The device in combination with the paediatric positioning system is intended to be used indoor and outdoor and only by children and adolescent users with the assistance of caregivers.

The ADACTA GIÒ frame can also be combined with the ERMES paediatric positioning system manufactured by Pro Medicare S.r.l.; in this case the instructions for combine the two devices can be found in the instruction manual of the paediatric positioning system; to know more about the frame for positioning system adjustments, warnings and restrictions, please read this instruction manual carefully.

The first commissioning, subsequent adjustments and Special Maintenance must exclusively be performed by the Professional User. If a custom-made Positioning solution is fitted and adjusted as prescribed, it may not be used for other users.

Any removal and/or changes of the standard configuration, and configuration for the specific user based on the prescription, must exclusively be performed by the Professional User and make it a custom-made Device.

The CE Declaration of Conformity refers exclusively to the Medical Device prepared and provided by the manufacturer, "as-is", when the Device is unchanged with respect to the standard configuration. The Professional User has the responsibility to guarantee the effectiveness and efficiency of the Device specially manufactured for the specific user.

Pro Medicare is constantly dedicated to innovate its own Devices; This can entail changes in form or technique on the devices and/or related accessories. Therefore, hypothetical complaints on values, images and schemes defined in the this manual, will not be accepted. Furthermore, for the complete list of the optional parts and/or accessories, please refer to the latest order form in force.

## 1. INSTRUCTIONS OF USE

### 1.1 Packaging and Transport

The original packaging contains the following components:

- frame for Positioning System with backrest tubes folded down, posterior wheels and footrest detached (when provided)
- any Accessories as per order form
- labeling and Instruction Manual.

Upon delivery, please check for the integrity of the package and immediately note any damages or anomalies on the shipping document. Then open up the packaging and check that the various parts do not show dents, drippings, deformations or tears. Otherwise note the anomalies found on the shipping document.

After performing these checks and if the product has not to be put into immediate use, we recommend to repack and store it in a dry place.

The above operation will be carried out by the Professional User who has to perform the assembling procedures of the Frame for Positioning System with the Positioning System.

### 1.2 Preliminary Operations for correct Commissioning

A positioning system produced by different manufacturing company, when installed on the ADACTA GiÒ frame, should have the seat and backrest with a proper mounting system for a good fit on the tubes of the frame (25mm).

The professional user and the end user need to check that the frame/posture connection system is safely manufactured.

The frame is delivered with all movable components disassembled; it is necessary to put it in service.



*These operations must exclusively be performed by the Professional User, who is responsible for the safety performance of the combination and/or configuration.*

#### 1.2.1 Operations for the "commissioning of the frame"

##### 1) Assembling the posterior wheels

To assemble the posterior wheels, insert the quick-release axle in the special bush fixed in the mounting plate (pic. 1), by pressing and then releasing the button. Verify the correct inserting of the wheels by checking:

- the release of the button of the quick-release axle;
- the impossibility of movement of the wheel.

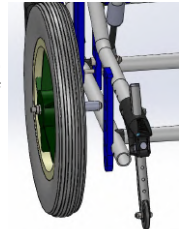

pic. 1: Assembling the posterior wheels

##### 2) Unfolding backrest tubes

Pull the backrest tubes by the push handles and bring them in upright position until you hear a click indicating the engagement of the lock pin. (Pic 2)

Verify the correct positioning of the backrest tubes by checking they are stable and do not rotate.

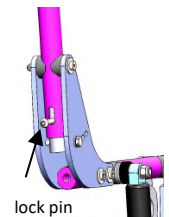

pic. 2: Backrest tube

##### 3) Inserting the legrest position (where provided)

Insert the extremity of the footrest hanger tube in the seat tube (Pic 3).

Push the tube until the pin locks in its housing.

Verify the correct positioning by checking the hanger is in position and doesn't come off.

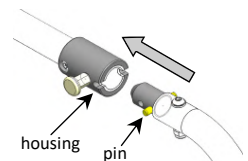

pic. 3: Inserting the legrest tube

#### 4) Checking the tyre pressure (where provided)

Ensure that the pressure is always as indicated on the tyre because the brake efficiency depends on it.

#### 5) Checking anti-tip system

\* Standard and fixed version (pic. 4.1):

This component reduces the risk of the structure tipping over under normal conditions of use.

The anti-tip system works properly (pic. 4.1) if they are between 25mm and 40mm from the floor;

if they are positioned too high they do not reduce the risk of tipping, if they are positioned too low they can hit obstacles.

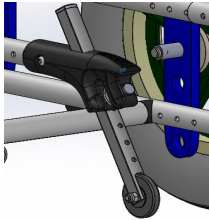

pic.: 4.1

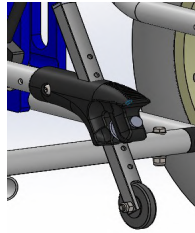

pic.: 4.2

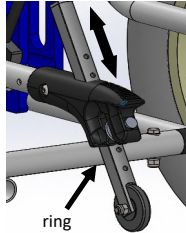

pic.: 4.3

To activate the anti-tip system (pic. 4.3) pull the ring outwards and slide the anti – tip system tube:

- pic. 4.2 shows the anti-tip system is positioned too high and it is not working properly

- pic. 4.1 shows the anti-tip system is positioned in a good distance from the floor and it is working properly

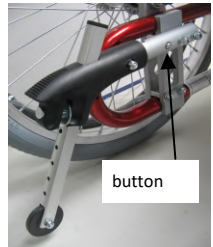

pic. 4.4: Detachable anti tip system

\* Detachable version (pic. 4.4) when provided:

This system can have the option to completely remove the anti-tip system from the frame only by pushing the pin showed in pic. 4.4. For inserting, squeeze the button and insert the tube by sliding it until the button stops in its housing.

Verify the correct operation by ensuring the impossibility of movement or detachment of the device from the frame.

See “Standard and fixed version” section to read instructions about the functioning



*It is absolutely forbidden using the anti-tip system, both in the standard and detachable versions, as pedal for overcoming barriers.*

#### 6) Checking the Parking Brake (pic. 5)

To activate the parking brake, push the lever forward until a “click” is audible and the brake is pressing against the tyre. Check that the wheel doesn’t move. Please release the lever to unlock the brake. To ensure that the wheel stops correctly, check that the distance between the brake and the wheel tyre is 6mm. If not, please adjust as follows:

- Unscrew the 2 brake clamp fixing screws
- adjust the distance between the brake and the wheel tyre (estimated value: 6mm)
- Screw the 2 fixing screws
- Check the wheels stop correctly.



pic. 5: Activating the brake lever

If the wheel is equipped with a drum brake, it is necessary to check for the proper function by activating the lever located on the backrest tube. Once the lever is activated, the wheels are locked with no possibility of movement. If the lever is not pressed, the wheels will be able to move freely. These brakes can be used to brake the system while is using. The braking force of the drum brake can be adjusted using the adjusting screw on the brake cable near the brake hub. The braking force can be increased by slightly unscrewing the adjustment screw. Loosen the nut and unscrew the screw until a friction noise is heard in the wheel rotation. Retighten the screw until the friction disappears. Tighten the nut to secure the adjusting screw.



*Take care to adjust the drum brakes on both sides of the frame in the same way*

## 7) Checking the Gas Springs

Verify that the gas springs do not leak oil. Check the functionality by activating the tilt mechanism ever located on the backrest tube.



*After all these operations please ensure that the frame moves easily and all components work properly. If you hear noise, vibrations or if there are any changes to the normal conditions of use, please contact the Professional User; He will check the safety conditions, the suitability for use and the effectiveness of the Device.*

## 1.3 Adjustments for the first Commissioning and/or subsequent adjustments

The Frame combined with the Positioning System is now ready to be used. Adjustments for the first Commissioning and subsequent adjustments to the changing needs of the end user are possible thanks to multiple adjustment possibilities of the frame. All possible adjustments are described in this chapter.

*These operations must exclusively be performed by the Professional User, who is responsible for the safety performance of the combination and/or configuration.*

### 1) Tilting seat (tilt in space)

The adjustment of the tilt in space is performed by two gas spring by operating the lever on the right hand push handle.

In this way the tilting of the seat is adjustable in a continuous way.

When the lever is released, the gas springs will block the seat at the reached position.

If this operation is performed with the user seated in the system, it is necessary to hold the push handles with both hands.

Then proceed by activating the gas spring and the tilt mechanism.

Please, perform this operation very slowly gradually and with care.

#### Increasing the initial tilting

This operation allows an increment of the final tilting degree by acting on the positioning holes of the front wheel in the predisposed holes of the fork; this means an inclination of the front wheel. The tilting of the frame generates a reduced mobility of the same, so this operation is strictly recommended when the pathology requires a high degree of tilting with reduced mobility of the frame. To adjust proceed as follows:

- unscrew the wheel fixing bolt in the fork
- engage the last hole in the fork
- tighten the relative self-locking nut without tightening it; regular tightening is obtained by checking that the screw protrudes from the plastic ring of the self-locking nut.



*While performing this operation, always ensure that the anti-tip system is fitted and correctly positioned and the user is well seated on the seat by wearing a pelvic belt.*

*Also ensure that the forearms are positioned on their upper limb supports to reduce the risk of trapping.*

### 2) Reclining the backrest

This adjustment is performed by engaging the desired hole located on the backrest tubes connecting plates. In particular (pic. 6):

- Lift the pin of the backrest tubes folding system placed on the lower end of each tube.

This operation will make the backrest tubes free;

- Unscrew the bolt that joins the two connecting plates of the backrest tubes

- Depending on the desired reclining value, insert the screw in the appropriate holes in the plate and screw it in without tightening the self-locking nut; the regular tightening is achieved by checking that the screw exits the thread from the plastic ring of the self-locking nut.

The holes allow the following values with respect to the vertical position:

- 1<sup>st</sup> hole = 3°
- 2<sup>nd</sup> hole = 10°
- 3<sup>rd</sup> hole = 18°

- Pull the backrest tubes and bring them in vertical position until you hear a click indicating the tube has been locked in position.

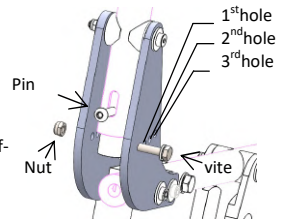

pic. 6: reclining the backrest



*Verify the correct position of the backrest tubes by checking they do not rotate.*

### 3) Adjusting the Footplates (where provided)

The footplates can be adjusted in height, depth, angle and internal/external rotation.

- **Height adjustment of the footplates**(pic. 7.1):
  - unscrew and remove the exagonal head fixing screw
  - move the fixing clamp along the hanger until the desired position is achieved
  - reinsert the screw in the appropriate hole and screw without thightening the self-locking nut;
  - the regular thightening is achieved when the screw exits from the thread of the plastic ring of the self-locking nut.
- **Depth adjustment of the footplates**(pic. 7.2):
  - unscrew and remove the 2 countersunk head fixing screws
  - move the footplate back and forth until the desired position is achieved
  - reinsert and thighten the screws firmly.
- **Angle adjustment of the footplates**(pic. 7.3):
  - unscrew and loosen the 2 countersunk head fixing screws
  - rotate the footplate clockwise or counterclockwise until the desired position is achieved;
  - reinsert the fixing screws and thighten securely.
- **Internal/external rotation adjustment of the footplates**(pic. 7.4):
  - unscrew and loosen the 2 countersunk head fixing screws without removing them.
  - rotate the footplate inwards or outwards until the desired position is achieved
  - screw and thighten them firmly.

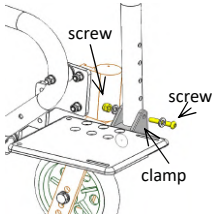

pic. 7.1: Height adjustment

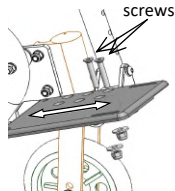

pic. 7.2: Depth adjustment

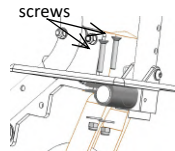

pic. 7.3: Angle adjustment

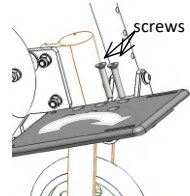

pic. 7.4: Internal/external rotation adjustment



After these adjustments, ensure that the footrests do not hit the castors.

### 4) Frame Depth Adjustment

The frame is delivered in its standard configuration. Depending on the user's needs, it is possible to adjust the depth of the frame as follows:

- **Anterior part** of 25mm by moving the legrest tube block
- **Posterior part** of 25mm by telescopic extension of the front tube
- **Posterior part depth adjustment (pic. 8.1):**
  - unscrew and remove the 2 fixing screws of the plates on the longitudinal tube
  - slide the plates along the tube by engaging the relevant holes of the desired value
  - insert the fixing screws and tighten to a torque level of 13.5Nm
- **Anterior part depth adjustment (pic. 8.2):**
  - unscrew and remove the fixing screw of the telescopic anterior tube
  - slide the anterior tube along the insert by engaging the relevant hole to the desired value
  - insert the fixing screw and tighten to a torque level of 13.5Nm.

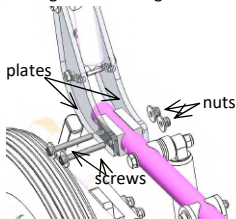

pic. 8.1: Posterior part depth adjustment

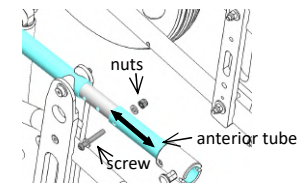

pic. 8.2: Anterior part depth adjustment



### 5) Frame Height Adjustment

The Frame Height Adjustment to 430mm and 490mm can be performed both with the 300mm and 500mm posterior wheels: Please refer to the following schemes to switch from one height to the other in function of the wheels provided.

#### √ 300mm WHEELS

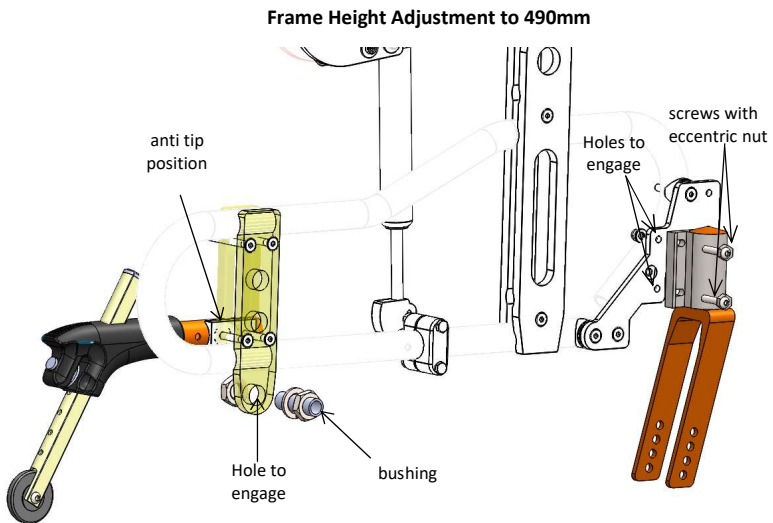
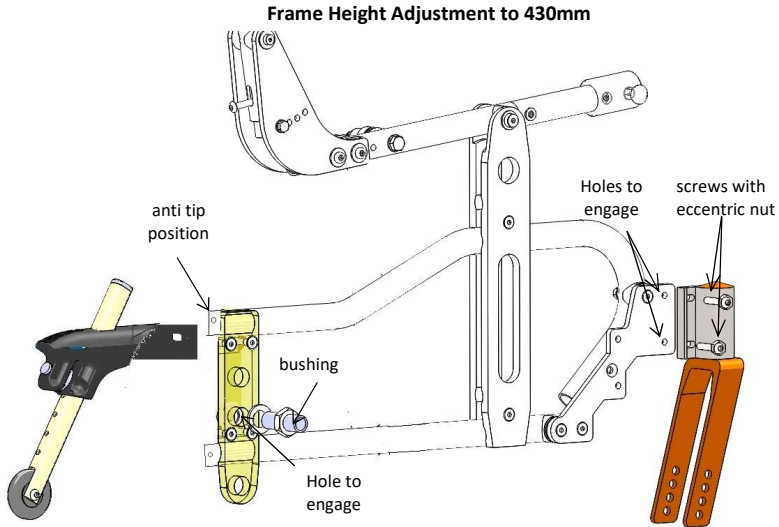

√ **500mm WHEELS**

**Frame Height Adjustment to 430mm**

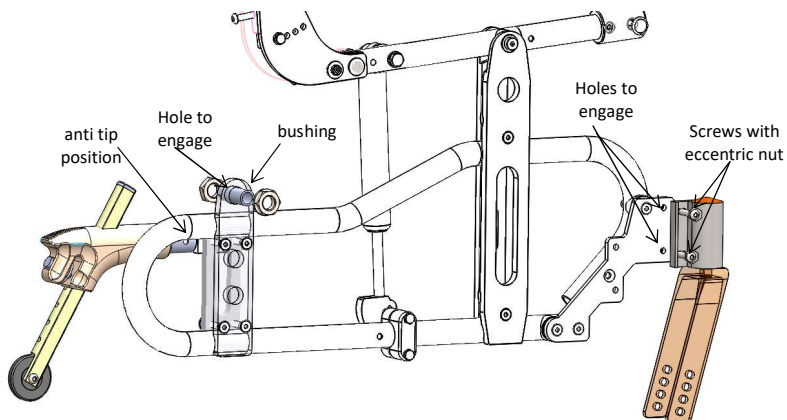

**Frame Height Adjustment to 490mm**

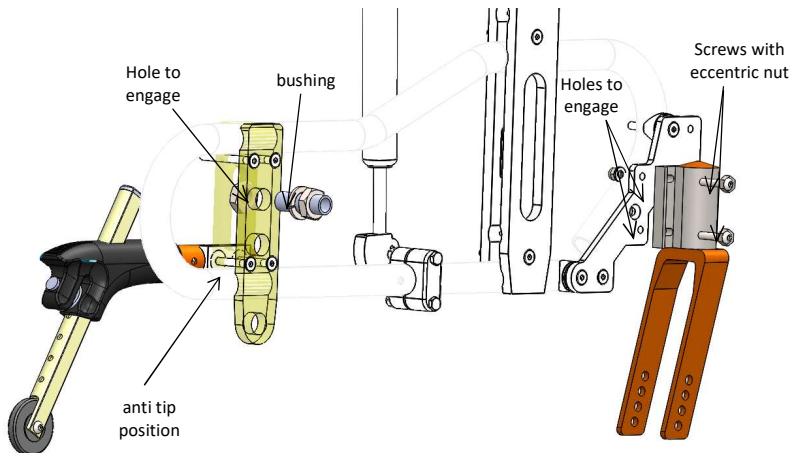

Once this adjustment has been made, it is strongly recommended to perform a reposition of the seat sliding plates in order to avoid unsafe tipping situations.

It is sufficient to perform movements by following the instructions reported in the section **6) Displacement of the plates** on page 11.

To change the Frame Height, please perform as follows:

**a) Change the position of the RH and LH forks**

- unscrew the two rounded head screws with eccentric nut connecting the fork to the plate
- engage the two relevant holes as reported in the scheme. Pay attention to the position of the eccentric nut: it has to be such that the fork axis is horizontal. Tighten at torque level of 13.5Nm.

**b) Repositioning the posterior wheels bushing**

- disengage the wheels mounted on the frame
- disengage the parking brakes
- remove the wheel drive bushing
- if needed, rotate 180° the outer plates of the wheels. To perform this operation, please, perform as follows:
  - \*unscrew and loosen the 4 countersunk screws locking the wheel plate
  - \*rotate the plates
  - \*insert the 4 countersunk head screws in the initial holes
  - \*tighten the screws with a torque of 13.5Nm
- mount the bushings by engaging the relevant hole as shown in the scheme
- firmly tighten the two nuts, placed one with washer outside to the plate and the other inside.

**c) Repositioning the Anti-tip System**

- remove the anti-tip device by unscrewing the bolt fixing it to the end of the frame.
- position the anti-tip device in the end hole of the frame as shown in the scheme
- insert and tighten the bolt with a torque of 13.5Nm.

**d) Mounting the posterior wheels**

Verify the correct functioning of the wheels by checking:

- The release of the quick release axis button
- The impossibility of the wheel to be detached.

**e) Mounting the parking brake**

For the correct parking of the wheels, adjust the distance between the brake pin and the tyre of the wheel by operating as follows:

- unscrew the 2 fixing screws of the brake clamp
- adjust the distance between the brake pin and the tyre of the wheel (estimated value 6mm)
- tighten the 2 fixing screws
- Verify the parking of the wheels.



After having performed these operations make sure that the Frame is easy to move and that all components work in harmony. If you hear noise, vibrations or if there are any changes to the normal conditions of use, please contact the Professional User; He will check the safety conditions, the suitability for use and the effectiveness of the Device.

**6) Displacement of the plates**

The frame is delivered in its standard features. Depending upon the users needs, it is possible the continuous horizontal displacement of seat with respect to the frame.

The displacement of the seat with respect to the frame can be done as follows (pic. 9):

- unscrew and loosen the countersunk screws fixing both plates of the tilting mechanism
- slide the tilt-in-space plates along the frame until the moving value *s* in the picture
- tighten the countersunk screws of the tilt-in-space plates to a torque level of 13.5Nm

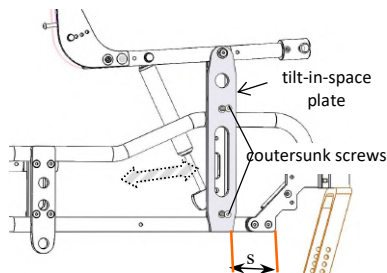

pic. 9: Displacement of the seat

### Moving value *s* for the displacement of the seat

√ **430mm Frame Height** (with 300mm e 500mm wheels) and **450mm Frame Height** (with 400mm wheels)

Frame size	1, 3	2, 4, 5	6, 7
Displacement (mm)	From 50 to 60	From 60 to 70	From 60 to 75

√ **490mm Frame Height** (with 300mm e 500mm wheels)

Frame size	1, 3	2, 4, 5	6, 7
Displacement (mm)	From 50 to 60	From 60 to 70	From 60 to 75

The displacement *s* is detected from the edge of the fork fixing plate to the first edge of the tilt-in space plate.

These values are indicative and can be changed by the professional user taking into account the type of combined positioning system (for example: backrests with considerable thickness, evident tilting and reclining).



*After each operation check the position of the brakes and, if needed, perform adjustment as reported on page 11 point e). After having performed these operations make sure that the Frame is easy to move and that all components work in harmony. If you hear noise, vibrations or if there are any changes to the normal conditions of use, please contact the Professional User; He will check the safety conditions, the suitability for use and the effectiveness of the Device.*

### 7) Knee Angle Adjustment (where provided)

- unscrew and loosen the fixing knob
- rotate the hanger until the desired position is achieved
- tighten the knob gradually so as the teathed mechanism engages and blocks the position of the hanger.

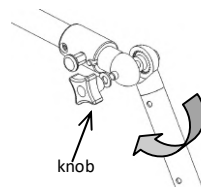

pic. 10: knee angle adjustment

### 8) Multiadjustable Kit (where provided)

This Kit allows to perform adjustments for the hip guides and arm support, in particular:

#### A) Pelvis

Possible adjustments are: in width, depth, height e adduction/abduction:

#### ◆ Width and/or adduction/abduction adjustment (pic. 11.1):

1. Loosen the locking lever to ensure the movement of the steel rod
2. Loosen the two cap screws to provide the movement of the hip guides
3. Move the hip guide to the outside and to the inside with adduction/abduction until the desired position
4. Tighten the two cap screws to block the hip guide

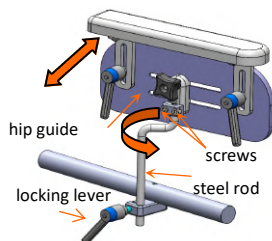

pic. 11.1 width adjustment

#### ◆ Depth adjustment (pic. 11.2):

1. Loosen the Knob to unlock the Hip Guide to the Clamp
2. Move Hip Guides horizontally and along the Slots until the desired position
3. Tighten the Knob to block the Hip Guide.

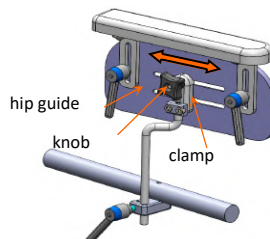

pic. 11.2 Depth adjustment

◆ **Height adjustment** (pic. 11.3):

1. Loosen the locking lever to ensure the movement of the steel rod
  2. Move Hip Guides vertically until the desired position
  3. Tighten the locking lever
  4. Put the collar on the clamp by screwing the two screws;
- To get the right position is important that the two Screws are oriented in the same direction of the locking lever.

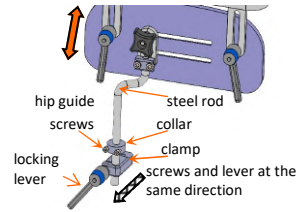

pic. 11.3: Height adjustment

B) **Arm Support**

The arm support is fixed to the hip guide through two slotted L-shaped brackets. The arm support present two rows of holes to allow multiple adjustments.

◆ **Height and/or tilt adjustment** (pic. 11.4):

1. Loosen the two locking levers to ensure the sliding of the brackets which are fixed to the arm support
1. Move the arm support vertically or tilt it until the desired position
2. Tighten the locking levers to block the arm support.

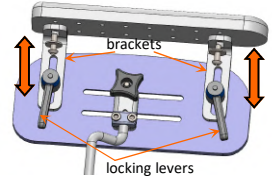

pic. 11.4: Height and/or tilt adjustment

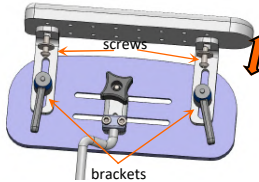

◆ **Width and internal/external rotation adjustment** (pic.11.5)

1. Unscrew and loosen the round head screws of the L-shaped Brackets which are fixed under the arm support
2. Slide Arm support inward or outward (internal/external rotation) until the desired position
3. Tighten and fix the Round head screws.

pic. 11.5: Width and internal/external rotation adjustment

◆ **Depth adjustment** (pic. 11.6):

1. Unscrew and loosen the round head screws of the L-shaped Brackets which are fixed under the arm support
2. Slide Arm support forward or backward until the desired position and in relation to the rows of holes located under the arm support;
3. Punch the cover, insert and fix the round head screws
4. Tighten and fix the round head screws.

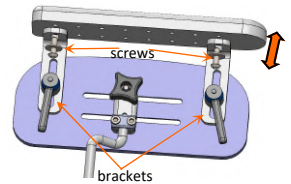

pic. 11.6: Depth adjustment



Ensure the multi adjustable kit works properly and safely by checking:

- 1) tightening of levers and screws
- 2) the impossibility of the hip guide and arm support to be detached

**9) Push Handles Adjustment** (where provided)

- **Telescopic Push Handles with Lever Block** (pic. 12.1)
- Loosen the locking lever of the telescopic push handles by lifting it up
- Adjust the height and/or orientation of the handles as desired
- Close the collar locking lever
- Make sure the handles are secure and do not allow any movement.



pic. 12.1: Lever block

- **Angle-adjustable single handlebar** (where provided) (pic. 12.2)

- Press the side buttons on the handlebar
- Adjust the orientation of the handlebar as desired
- Release the side buttons
- Make sure that the two side buttons have been released.



pic. 12.2: Angle-adjustable single handlebar

## 10) Flip back Tubular Armrest (where provided)

The armrest is mounted to the backrest tubes by means of mechanical clamps (pic. 13) and it can be angle and height adjustable ( $\pm 2.5^\circ$  with respect to the horizontal plane).

### ◆ Height adjustment

1. unscrew and loosen the countersunk screw and the hexagonal screw of the eccentric pawl
2. slide the clamp on the backrest tube until the desired height is achieved
3. re-tighten the screws

### ◆ Angle adjustment

1. unscrew and loosen the hexagonal screws locking the eccentric pawl
2. rotate the pawl of the armrest at the desired inclination
3. re-tighten the hexagonal screws

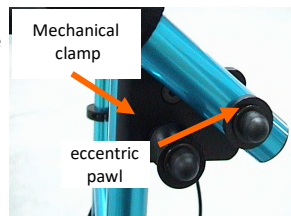

pic. 13: Armrest

## 11) Legrest containment (where provided)

### A) Calf Support

The single or separate Calf Support (pic. 14.a) provides the posterior and lateral containment of the leg.

It can be adjustable in height, by engaging the holes (placed at a distance of 25mm) drilled on the hanger, or in depth by engaging the holes drilled on the rear part of the same hanger.



pic. 14.a Calf support

### B) Calf Strap (pic. 14.b)

It provides support at the posterior part of the leg, preventing it from sliding backwards, and guarantees a good positioning of the foot on the footplate; this fitting is performed by the fastening system.

To assemble it, please proceed as follows:

- 1) determine the position along the tube where the strap needs to be mounted
- 2) adhere the adhesive tape to the tube which is at the end of the strap
- 3) insert the ring-shaped ends of the strap into the two legrest tubes and fix them onto the adhesive tape placed in the previous step)
- 4) adjust the padding of the Calf Strap by using the fastening system to give a correct support to the leg.



pic. 14.b Calf strap

## 12) Seat Base (where provided)

The seat base (pic. 21) has the purpose to accommodate the positioning system and its accessories.

It can be:

- **Grey color.** Along its lateral edges it is featured of rows of threaded holes (at a distance of 25mm) and 2 interlocking clamps both in the anterior and posterior parts that allow the mounting of the base on the frame.

So that, lay the wooden base onto the tubes by paying attention to the position of the interlocking clamps: for a good installation they should be positioned one in front and one behind the 2 collars mounted on the tubes. This operation impedes the movement of the seat backwards or forwards. The adjustments can be done by sliding the interlocking clamps along the the edges of the seat base or the relevant collars along the tubes of the seat by operating through the screws. After positioning, push the seat on the tubes until you hear a locking click to indicate the 4 interlocking clamps have grafted the tubes. If there are securing clamps, you have to close them tightly on the tube after positioned.

- **Raw (only wood) with mounting kit.** It is featured of 1 row of holes (at a distance of 25mm) along the lateral edges, where the provided threaded t-nuts have to be inserted. Lay the wooden base on the seat tubes and detect 2 holes both in the anterior and posterior parts where the threaded nuts have to be inserted for the fixing of the interlocking clamps. The threaded nuts have claws that have to be completely embedded in the wood (even with hammer). The interlocking clamps have to be mounted on the face opposite to the threaded nuts. Pay attention to the 4 interlocking clamps and the 2 collars on the tubes: for a good installation the collars have to be mounted in strictly contact with the relevant clamp and be positioned alternatively one in front of the clamp in the anterior part of the base and the other behind the clamp on the opposite side in the posterior part. This operation impedes the movement of the seat backwards or forwards. After positioning, push the seat on the tubes until you hear a locking click to indicate the 4 interlocking clamps have grafted the tubes. If there are securing clamps, you have to close them tightly on the tube after positioned.



Verify the correct mounting of the seat base by checking the impossibility of movement when:

- it is moved back and forth along the seat tubes of the wheelchair
- it is pulled upward

### 13) Tray (where provided)

The grey color or transparent tray, depending on the relevant fixing hardware, can be folding or removable

Any shape of tray can be fixed to the armrests or arm supports by detachable or lateral flip mechanism. It is secured as follows:

#### (option 1) Detachable mechanism (pic. 15.1)

- verify that the fixing L brackets firmly grip the arm supports/armrests. In a contrary case, please remove the pin and move it to a most suitable exagonal shaped hole onto the lateral edges of the tray.
- strongly tighten the locking knob
- check the tray is stable.

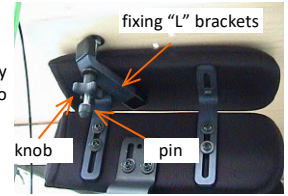

pic. 15.1: Detachable mechanism

#### (option 2) Lateral Flip mechanism

The mounting can be done as follows: (the pic. 15.2 shows the hardware only):

- mount the guide tube with its clamping knob under the arm support
- insert the rod of the hardware in the guide tube
- tighten the knob firmly
- tighten and fix the round head screws
- check the tray is stable.



pic. 15.2: Lateral Flip mechanism



Verify the correct mounting of the tray by checking it doesn't move when pulled in all directions. Verify its stability.

### 14) Canopy (pic. 16)

#### Mounting

- Tighten the collars at the top of the backrest tubes using the screws provided
- Connect the fixing bracket with the steel rod through the holes provided
- Insert the locking lever in the appropriate seat as in the figure.
- Adjust the width of the canopy by holding the two hooks and moving outward or inward, according to the needs
- Insert the hooks of the canopy on the fixing bracket, making sure that the hook is fully locked in its position
- Pull the canopy handle downwards according to the needs leaving the appropriate space for the user's head.



pic. 16: Canopy



Do not expose your child to the sun. The canopy will not protect the user from sun damage.

#### Removal

Press the hook tabs and lift the canopy up.

## 1.4 How to use it

The frame combined with the positioning system, after the Professional User has performed the commissioning, is ready to be used.

Daily operations such as the transfer from and to the system, must normally be performed by parents or caregiver. Following there are all modes of use. Before to start any operation the caregiver or parents need to be instructed by the professional user. It will require some degree of training and practice to master all operations in a safe manner. It is good to develop one's own methods for safe use, adapted to the needs.



During daily use it may happen that components and/or accessories become loose, affecting adjustments, this is why it is recommended to schedule a follow-up to monitor and check the posture. Never make any adjustments or changes without the intervention of the Professional User.

### a) Use of the Frame Components

- **Backrest Tubes: engagement/disengagement** (pic. 17)

#### Engagement

Pull the backrest tubes by the push handle in vertical position until you hear a click indicating the engagement of the lock pin.

Verify the correct position of the backrest tubes by checking they are stable and do not rotate.

#### Disengagement

Lift the pin of the backrest folding system placed on the lower end of each backrest tube. This operation will make the tubes free to be folded.

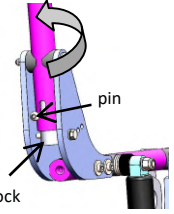

pic. 17: backrest tube

- **Legrest Tubes: engagement/disengagement**

#### Engagement (pic. 18.1)

- Insert the edge of the legrest tube into the seat tube

- Push the tube until the lockin pin stops in its relevant housing

- Verify the correct assembling by checking the Legrest tube is in place and doesn't move or rotate.

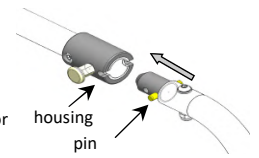

pic. 18.1: Engagement

#### Disengagement (pic. 18.2)

- Pull the spring loaded locking pin outward.

- Remove the Legrest tube.

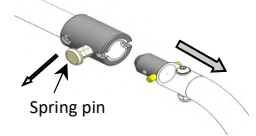

pic. 18.2: Disengagement

- **Anti Tip System: engagement/disengagement**

please, follow the instruction reported on page 6 point 5.

- **Parking brakes**

The frame is provided with two parking brakes. To activate the brake, press the lever downward until you hear a blocking noise indicating the engagement of the brake; check that the wheel doesn't move. To unlock the brake, pull the lever in its original position. The brakes are designed to be used as parking brake and do not have to be used while the frame is running.

For the correct parking of the wheel, check that the distance between the brake peg and the wheel tire is equal to 6mm. In a contrary case please refer to the professional user for its adjustment. If the wheel is equipped with a drum brake there will be two lever located on the backrest tubes. Once the levers are activated, the wheels will be blocked without possibility of movement; if the levers are released the wheels will be free to move. These brakes can be used to stop the system while it is running.



*When the frame is running and the drum brake has to be activated, it is necessary to operate both levers at the same time. The adjustment of the parking brake and of the activating drum brake levers must be performed by the professional user.*

- **Tyres**

Check that the pneumatic wheels are inflated as the value reported on the side edge of the tire. Improper pressure can influence the performance of the Frame: low values can affect the manoeuvrability and action of the brake; high values can cause the tyre to burst. The replacement of the inner tube and / or tyre is like any bicycle wheel. Also check the tire profile: excessive wear can reduce the action of the parking brake.

- **Versa-Fixatis fixing elements** (where provided)

The positioning system may include the FIXATIS Range fixing elements.

To know more about their use, please, refer to the accompanying manual.



Before using the system, make sure that fixing elements are secured.



- **Multiadjustable kit** (where provided) (pic. 19)

Disengagement (pic. 19.1)

1. Loosen the locking lever and release the steel rod
2. Remove the kit.



*Pay attention during removal, to avoid hitting against end user*

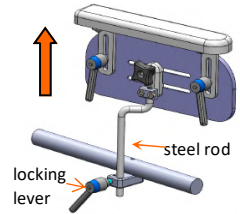

pic. 19.1: Disengagement

Engagement (pic. 19.2)

1. Insert the steel rod into the hole of the locking clamp.
2. Slide the rod until the collar is in contact with the clamp.
3. Pay attention to the two screws on the collar; to ensure the correct position, the two screws must be oriented in the same direction of the locking lever.
4. Tighten the locking lever.

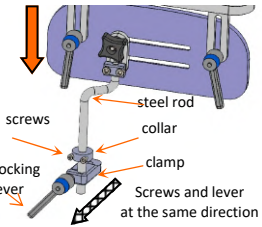

pic. 19.2: Engagement

*Make sure the multi adjustable kit is working safely by checking:*

- 1) the tightening of the locking lever
- 2) the screws of the collar and of the locking lever must have the same direction
- 3) the kit cannot be detached



- **Tray** (where provided)

Please follow the instruction reported on page 15 Point 13

- **Footmuff** (pic. 20)

Mounting

The footmuff can be easily installed without tools by proceeding with the following steps.

- Position the footmuff (remove wrinkles) to fit the seating system and provide optimal comfort.
- Insert the footmuff in the lower part of the seating system
- Attach the hook-and-loop fasteners located along the ends of the footmuff to the frame, according to the needs.

Footmuff removal

Remove the hook-and-loop fasteners located along the ends of the footmuff from the frame and remove the footmuff.



*Do not smoke and/or come into contact with heat sources, this may cause product flammability*



pic. 20: Footmuff

- **Basket** (pic. 21)

Mounting:

- Place the basket in the lower part of the frame
- Attach the supplied pieces of hook-and-loop female sides to the desired position on the underside of the frame
- Attach the hook-and-loop fasteners located along the ends of the basket to the frame, overlying them to the others previously attached.

Removal:

Remove the hook-and-loop fasteners located along the ends of the basket from the frame and remove the basket.



*Do not smoke and/or come into contact with heat sources, this may cause product flammability*



pic. 21: Basket

- Rain cover (pic. 22)

Mounting:

- Unbox the rain cover

- Position the rain cover (remove wrinkles) to provide optimal comfort

Removal:

- pull off rain cover from its ends, so remove it.



pic. 22: Rain cover



*Do not smoke and/or come into contact with heat sources, this may cause product flammability*

### b) End-user transfer from/to the System

Before performing these operations, it is important to discuss with the end user and about the most natural and regular operations that needs to be done. This will help to make it easier for the user and it will reduce possible dangers.

#### Transfer from the System

- ✓ Ensure the brakes are on, and the frame is locked from movements
- ✓ Ensure the anti-tip device are correctly positioned
- ✓ Put the seat into a horizontal position by operating the tilting lever
- ✓ Loosen any fixing harness
- ✓ Disengage any thoracic supports and hip guides
- ✓ Disengage the legrest by tilting the legrest tube to the side to reduce the risk of trapping feet during transfer.

Now the user is ready to be transferred. Please pay particular attention to this operation.

#### Transfer to the System

- ✓ Engage the brakes and make sure the frame is locked
- ✓ Ensure the anti-tip device are correctly positioned
- ✓ Put the seat into a horizontal position by operating the tilting lever
- ✓ Lift and transfer the user to the system by paying particular attention to this operation
- ✓ Engage any thoracic supports and hip guides
- ✓ Position and adjust the legrests
- ✓ Fasten any fixing components
- ✓ Make sure that the user is in his normal seating position.



*While the positioning operation is ongoing, ensure that no part of the body is trapped.*

### c) Tilting the System

The tilting of the System is performed by activating the gas springs which are controlled by the lever located on the push handles of the backrest or with pedal. Adjust the system according to the instructions of the professional user. Tilting must be continuous and, when the lever/pedal is released, the springs will lock the seat in the position reached. The procedure is described below:

- 1) Apply the brakes and ensure the frame cannot move
- 2) Grip the push handles using both hands
- 3) Press the lever, push the handles down; tilt the frame gently and with slow movements
- 4) Release the lever when the desired angle of tilt is reached. In this way the seat will stay in such position.



*During the adjustments always ensure the anti-tip system is correctly activated and that the user is well placed in the seat using the pelvic belt. Also make sure that the forearms are positioned on the relative upper limb supports in order to avoid the risk of entrapment.*

#### d) Transporting the System

For an easy transportation of the system, it is necessary to proceed with the removal of the Positioning Systems from the Frame by carefully following the steps below:



*Pay particular attention to the following operations; do not lift the backrest by the thoracic supports and the seat by the armrests: they can become loose and change the configuration of the System. Lift only by the components that cannot be detached. Be careful when folding the System as to not trap any moving part. Finally, upon reassembly, check that all configuration and settings have not been altered. If changes are noted, please contact the Professional User.*

##### - Disassemble the Positioning System from the Frame and make it compact for transportation in a vehicle

In order to transport the system in a vehicle, it is necessary to remove the Positioning System from the Wheelchair Base:

- 1) Apply the brakes ensuring the frame cannot move
- 2) Remove the seat: if there are 2 snaplock clamps, loosen and pull the seat with the wooden base upwards until it clicks, indicating that the seat clamps are detached from their relative tubes
- 3) Remove the backrest: follow the instruction reported in the relevant Instruction Manual
- 4) Remove the Kit ABS Lateral
- 5) Folding down the backrest tubes; follow the instruction reported on page 16
- 6) Remove the posterior wheels: release the parking brake by pressing the quick-release axle button and pull out the axle with the wheel
- 7) Remove the legrest tubes: follow the instruction reported on page 16
- 8) Disengage the anti tip system: follow the instruction reported on page 6

Now the seat, backrest and frame can be placed in a vehicle.

##### - Subsequent start-up of the Frame and recombination of the Positioning System with the Frame

At the end of the trip, bring out the frame, the seat and the backrest from the vehicle and proceed with the following operations:

- 1) Assemble the posterior wheels: follow the instruction reported on page 5
- 3) Assemble the backrest tubes: follow the instruction reported on page 16
- 4) Assemble the legrest tubes: follow the instruction reported on page 16
- 5) Apply the parking brake and make sure the frame doesn't move
- 6) Fix the seat; please, follow the instruction reported in the relevant instruction manual
- 7) Fix the backrest: follow the instruction reported in the relevant instruction manual.



*After having performed these operations make sure that the Frame combined with the Positioning System is stable, easy to move and that all components work in harmony. If you hear noise, vibrations or if there are any changes to the normal conditions of use, please contact the Professional User; He will check the safety conditions, the suitability for use and the effectiveness of the Device.*

## 1.5 Recommendations for Use

In order to guarantee safe use and a long lasting performance of the Frame for Positioning System, please find below advices for the user:

- √ Carefully follow the instructions reported in this manual
- √ Follow the recommendations provided by the Professional User
- √ Keep the Device away from heat sources
- √ Avoid using armrests as a support base for the user
- √ The brake is designed for the parking and not for slowing or stopping the wheelchair while it is running.
- √ Carry out thorough cleaning and pay close attention to the standard maintenance.

## 2. GENERAL WARNINGS

All announcements reported in this section describe the conditions and situations that may cause danger to the user or to third parties. Please read carefully before using and putting the in service the System. To ensure the correct use of the Device, some operations, such as the first commissioning and adjustments, must only be performed by authorized people - *the Professional User* - Some daily operations can obviously be performed by the *End User*. Therefore, there will be specific warnings for those concerned. In particular, the term *Professional User* describes the suitably qualified person (authorised dealer, orthopaedic technician, occupational therapist, healthcare professional, etc.), while, the term *End User* describes the person who is intended to use the Device (caregivers, family members, etc.).

## 2.a) Warnings for the Professional User

For further information, please contact the Technical Sales Department at the following number :

+39 0831 777840

- **Max. Load:** See Annex A “*Technical Features*”
- **Preliminary Operations for correct Commissioning:** (to be performed in accordance with the instructions provided in *section 1.2*)
  - \* After having performed these operations make sure that the Frame combined with the Positioning System is stable, easy to move and that all components work in harmony
  - \* Check for noise, vibration, or changes to the normal conditions of use to ensure safety conditions and the suitability for use.
- **Adjustments:** (to be performed in accordance with the instructions provided in *section 1.3*)
  - These operations must be performed by authorized people
  - During these adjustments, the anti-tip castors must be positioned to reduce the risk of the System tipping
  - After having performed these adjustments, be aware of any noise, vibrations or any changes to the normal conditions of use
  - Unauthorized modifications or the use of parts not supplied or approved by the manufacturer may affect the safe and operational integrity of the system and be cause of danger.

## 2.b) Warnings for the End User

Before using the Device ensure the Professional User explains the procedures for correct commissioning and standard maintenance for further information, please contact the Professional User.

- **Maximum Load:** See Annex A “*Technical Features*”

### - Environmental Conditions

- a. The Frame for Positioning System is designed for use on hard surfaces such as asphalt and paving, so:
  - Do not take the wheelchair onto sand or rough terrain. This can cause damage to the wheels, axles and other components of your wheelchair
  - Use extreme caution and care if you use the wheelchair on wet and/or smooth surfaces.
- b. Contact with water and excessive moisture can cause components of the structure to oxidise and start to show signs of decay, so:
  - Do not use the wheelchair in the shower, pool or environment in contact with water. Some components may be damaged and cause malfunctions
  - Avoid extreme humid places (for example: do not bring the wheelchair into a steamy bathroom after a shower)
  - Avoid contact with seawater
  - If the wheelchair comes in contact with water or dirt, please carry out an immediate and thorough clearing
- c. Severe environmental conditions may affect the features of the materials used, the functionality and performance of the structure, so:
  - Avoid the exposure to extreme temperatures
  - Avoid prolonged exposure to sunlight. Some parts (for example the base, parking brakes, footrests and the positioning system) may overheat.

### - Components and Options

**Anti Tip System:** This device reduces the risk of the wheelchair tipping backwards in normal conditions of use. If locked in position (downwards) the anti-tip tubes must be at a distance between 25-40mm from the floor; if they are placed too high, they do not reduce the risk of the wheelchair tipping and if too low, they can come in contact with surfaces and obstacles during normal use. Always keep the anti-tipping tubes locked in position when the end user is left alone on the base, when the system is running, make sure that the anti-tip tubes have been placed upwards.

**Footrests:** The footrests are the lower part of the frame and closer to the floor, so avoid to pass over obstacles that may collide with them causing damages. Also:

- Make sure user's feet do not “hang” over or become trapped between the footplates
- Do not place any weight on the footrest to prevent the wheelchair tipping forwards
- Do not stand or lean on the wheelchair footrest; they may detach from the footrest tubes or break.
- Make sure, after each adjustment, that the footrest doesn't touch the front wheels.

**Posterior Wheels:** Every time the wheels are re-inserted please check for the correct assembly. So check:

- the quick-release axle has been activated
- the impossibility of the Wheel to be detached
- check that the pressure of the pneumatic tyres is equal to the value indicated on the tyre, as the efficiency of the brakes depends on this.

**Armrest:** The armrests cannot support the weight of the wheelchair. if used for lifting the chair, they may become damaged and can break.

**- Use**

- **Maximum Load:** See “Technical Features” reported on the Annex A
- If you hear noise, vibrations or any abnormality after a few days of use, please contact the professional user
- Be careful when moving the wheelchair over uneven ground or obstacles, which if in contact with wheels, they can cause the wheelchair to tilt.
- To reduce the risk of a tipping, do not hang bags, backpacks or any other weight on the system
- Max accepted gradient: 7°
- In the event that an accident causes a loss of performance, do not use the system and consult the professional user
- In the case of a sudden deterioration in performance, do not use the system and consult the professional user
- Never perform any adjustment or change without the intervention of the professional user
- In case of malfunctions resulting from other causes, including poor maintenance of the wheelchair, the professional user should be consulted.
- For the cleaning operations do not use aggressive products which may affect the oxidation and/or cover
- Frequently check all the connections between the positioning system and the frame and verify for a safe and fully functional operations.
- Pay attention to the hands when opening the footrest platforms.

### 3. NEGATIVE ADVERSE EFFECTS

Generally the use of the system should not cause any adverse effects such as allergies, skin irritations or redness (the cover is latex-free, is at low risk of irritation to the skin and it is commonly used in medical devices). Otherwise, please contact the Professional User immediately. Daily monitor the skin area which is in contact with the Device for evidence of pressure sores caused by incorrect or outdated adjustments; in this case it is suggested to suspend the use and contact the Professional User.

### 4. RESTRICTIONS OF USE

The Frame for Positioning System has been designed and manufactured to provide the end user the correct positioning support within the normal activities of daily working life, social relations, school or leisure time. Any other use may compromise the safety of the Device.



*Mandatory Requirements*

- When the wheelchair is in tilted position, the anti-tip system should always be in function
- The anti-tip system should never be removed from the wheelchair
- Do not drill or crush the gas spring
- Do not drive the wheelchair with the seat fully tilted on steep slopes.
- When the system is not tilted, make sure the user is not too forward in the seat to avoid compromising the stability of the wheelchair.
- When the user is on board, avoid lifting the wheelchair by the legsrests or any posture accessories. If it is necessary, lift the wheelchair by the sides of the base structure, making sure the seat assembly doesn't move during this operation
- Get help from additional people when you have to lift the wheelchair over obstacles or down stairs
- All replacement parts or adjustments not authorized by the manufacturer are strictly forbidden
- For safety, never leave the user alone in the wheelchair, especially in the case of children
- If a stair lift platform is to be used, please contact the Company
- Apply the brakes whenever wheelchair-user is stationary
- Please, pay particular attention when moving on rough or uneven terrain which can damage the system
- It is recommended to never use any type of positioning harness/belt as a safety belt
- It is not recommended the use of the System for users who need shock absorbing/dynamic systems.
- Smoking and/or open flames are prohibited

## 5. STANDARD MAINTENANCE

In order to guarantee a good functioning and long lasting performances in safe conditions it is necessary to check regularly and make periodically maintenance. This operation must be performed by the end user. The regular maintenance consists of two parts: cleaning and mechanical parts checking.

### - Cleaning -

The metal and plastic parts can be cleaned with a damp cloth with cold water without addition of detergent, taking care to go over everything with a dry cloth. Mechanisms such as the backrest reclining plate, tilting mechanism, parking brake and anti-tip wheels, should always be checked to remove any dust or dirt that may affect performances. We recommend these operations at least once a month.

### - Mechanical Parts Checking -

The following operations have to be performed:

- Daily check the functionality of the brakes
- Weekly check the tyre pressure. Please refer to a qualified professional for inner tube replacement;
- Monthly check for tyres wear
- Monthly monitoring of parking brakes efficiency and the initial adjustments performed by the clinical professional or authorised dealer; verify that the distance between the tyre surface and the brake pin is 6mm and the operating force does not exceed 60N;
- Monthly inspection the drum brake cable and adjustments
- Monthly inspection the tension of the cable for the proper operation of the gas spring
- Monthly check the screws and their tightening mechanism
- Quarterly oiling the quick-release pin of the folding back canes, the hubs and axles of the wheels, the brake pins, the screw of the footrest hangers
- Check the adjustments: it is strictly recommended to respect the program of the checks and monitoring scheduled with the professional user.

## 6. ADAPTATIONS WITH STRUCTURAL CHANGES AND/OR SPECIAL MAINTENANCE

Special maintenance should be performed when one or more structural components deteriorate in such way to compromise the performance and safety of users. In this case do not use the Device and immediately contact the Professional User who shall promptly inform the manufacturer about the nature of the malfunction and/or the failures found in order to proceed with the necessary interventions.

The instructions below must be followed at all times:

- Tyre wear: the tyre can be replaced by qualified professional using one with the same dimensions and features of the original. The professional user should then provide for the adjustment of the parking brakes and their efficiency.
- Components failure such as wheels, forks, brakes, anti-tip castors, pushing handles and screws: they must be replaced with original parts provided by the manufacturer, restoring the original safety conditions
- Components Breakages or tears such as plates, tubes, linkage components: they must be replaced with original items provided by the manufacturer
- For all structural components it is strictly forbidden to perform any repair and repair by welding, bolted or riveted joints
- We recommend a gradual adaptation of the system to any user's needs.

The non observance of the above clauses will automatically void the CE mark.

For special maintenance, the End User must refer to the Professional User who has to send the appropriate form *Annex 1* to the manufacturer within 24 hours of the request for intervention.

## 7. PERFORMANCE AND DURABILITY

Pro Medicare S.r.l. ensures that its own production of Frames for Positioning Systems and/or accessories have been designed and produced in compliance with the safety regulations as required by the relevant Regulation (EU) 2017/745.

The benefits provided by the above mentioned medical devices, either individually or in combination, are therefore suitable and respond to the project's purpose, which is the mobility of users with severe disabilities, considering a more effective rehabilitation plan based on correct posture and stability.

The realistic life span of the Adacta Frame for Positioning System Range is 5 years, while the realistic life span of Versa Positioning Systems Range is approximately 3 years .

These values are purely indicative because, even if the duration expected in the design phase is much greater, it is significantly determined by the way the device is used, by the correct use and careful maintenance.

It is also reasonable to consider a slight reduction in performance over time due exclusively to:

- shocks and accidental events

- natural wear of the components.

Both performance and relative life span expectancy are however dependent by the periodic verification of the suitability, combination safety and the right System adjustments and have to be exclusively performed by the Professional User; regular reassessment by the professional user should therefore be provided in order to check the suitability, safe and integrity of the system. If the Professional User deems it necessary, he can make adjustments to provide the right support and maintenance. The reconditioning of the device is prohibited if not expressly authorized by the manufacturer.

## 8. WARRANTY

Pro Medicare S.r.l. warrants the devices functionality for a maximum period of 24 months, covering all manufacturing defects from the first commissioning and 12 months on components and covers replaced under special maintenance starting from the date of commissioning after refurbishment and 12 months for wear parts.

The warranty is valid if the device is used as indicated within this instruction manual.

The warranty is voided in the following cases:

- improper use and/or in case of force majeure
- improper and/or inappropriate use for users affected by high tone and/or movement disorders
- a failure arising from an unauthorized tampering or faulty maintenance by third party that compromises the correct functionality and safety of the products
- any modification made without the manufacturer's authorization
- accidental damages and wear of the essential components
- structural changes of the end user
- failure or damages during the transportation: the Professional User is pleased to refer to the general sales conditions
- Stolen or loss.

For warranty replacement of components, the End User must refer to the Professional User who has to send the appropriate form *Annex 1* to the manufacturer within 24 hours of the request of intervention.

It is also essential for the manufacturer to receive a completed *Warranty Registration Form*.

## 9. POST-MARKET SURVEILLANCE AND POSSIBLE INCIDENTS

Pro Medicare S.r.l. ensures that their medical device products have been manufactured within the strict compliance, criteria and requirements established by the relevant applicable standards, guarantee functioning under the safety conditions prescribed by Regulation (EU) 2017/745. In accordance with Regulation (EU) 2017/745, Pro Medicare S.r.l. ensures and implements, pursuant to art. 83, a post-marketing surveillance system useful to monitor and ensure a clinical follow-up, in the period following the placing on the market, the degree of reliability and clinical efficacy of the medical device and in the constant search for quality improvement of the devices themselves. These activities are also ensured through an accurate market surveillance of the medical devices already on the market, as also provided by art. 84 of the same Regulation (EU)2017/745.

To ensure Post-Market Surveillance, Pro Medicare S.r.l. shall implement all activities together with Professionals and Stakeholders to establish and keep updated a systematic procedure which is useful to collect and promptly analyze the experience gained on devices that have been placed on market, in order to identify any need for improvement or modification.

The post-market surveillance system is established and implemented in accordance with the Pro Medicare's Quality Management System and is designed to actively and systematically collect, record and analyse relevant data on the quality, performance and safety of its devices throughout their lifetime, to draw the necessary conclusions and to determine, implement and monitor any preventive and corrective actions.

The post-market surveillance system also the monitoring of any incidents with the use of the device that may have caused serious physical harm to end users, caregivers or to professional users.

The result is that, in the event of any incidents, pursuant to art. 87

### IT IS MANDATORY TO SEND TO THE MANUFACTURER

a copy of a fully completed *Annex 2*.

Pro Medicare S.r.l., as soon as it receives the above-mentioned form, will provide the appropriate communications to the professional and to the end user, including the possible authorisation to repair the damaged device or to replace it and according to the nature and gravity of the incident detected.

IN URGENT CASES IT IS RECOMMENDED TO CALL THE MANUFACTURER AT THE FOLLOWING NUMBER

**+39 0831 777840**

SENDING TO FAX THE COMPLETED *ANNEX 2* AS SOON AS POSSIBLE.

Please note that the Professional User together with Pro Medicare S.r.l. have to communicate incidents also with serious consequences, pursuant to art. 87 of the Regulation (EU)2017/745.

The Form is available for download on the Ministry of Health Website or could be provided on request by Pro Medicare.

## 10. DISPOSAL/RECYCLING

Please, follow the local disposal and recycling regulations.









Following there is the description of all materials used (It is recommended to proceed with a separation of the different components of the Positioning System accessories) :

- **Aluminium:** headrest hardware, various type of brackets, tubes, plates, forks, footrest, backrest shell, 500mm and 600mm posterior wheels
- **Steel:** screws, threaded inserts, headrest shell, quick-releases
- **Wood:** seat bases, calf support bases, support bases, hip guide bases, trays, abductor wedge base
- **Plastic:** internal thoracic support bases, mounting components of the base on the frame, handgrips, castors, 300mm posterior wheels, footplate, fixing elements of harnesses, seat/back structural kit, various type of padding, packaging
- Synthetic fabric covers (polyester, elastane, etc.) and padding belonging to the polyethylene or polyurethane foam family
- **Paper:** cartoon or wrapping paper.

## 11. LABELING

The label is placed on the lower side of the frame and it is also stucked on the second page of this manual.

Product data are indicated on the label. In case of replacing parts orders and/or reports, the serial number of the product is duly requested. A facsimile of the label is shown below:

 <p>Pro Medicare S.r.l. Via Montagna Z.I. Lotto 41 72023 Mesagne (Br) Italy tel: +39 0831 777840 fax: +39 0831 730739 e-mail: sales@promedicare.it p.i./vat n. 01803920741 MADE IN ITALY</p>	<p><b>REF</b> _____</p>
	<p><b>SN</b> _____ <b>Max. Load</b></p> <p>       </p>



Manufacturer



Medical Device



Handle with care



Recovery/Recyclable



Consult Instruction for Use



Keep dry



CE Mark



Serial Number



Catalog Number



### Annex - A “Technical Features”

This annex describes the *ADACTA GIÒ Frame for positioning system*, its technical and functional features. It is an integral part of the instruction manual. For further information please contact our Technical Sales Department at the following number:

**+39 0831 777840**

The bases of this range are made of high-strength aluminium used in the aeronautical industry, and allow significant adjustability and adaptability which ensure a seamless modularity and interchange of components to continually evolve with the users changes.

This makes it always adjustable to the user's needs by providing the possibility to periodically change the system, this is a necessary operation especially for developmental disabilities.

The satin finish frame for positioning system can have various colors of plates.

The tilting mechanism is always adjustable by operating the two gas spring lever located on the push handles. Depending on the type of the fixing plates, it is also possible:

- seat depth adjustment (for a total of 50mm)
- sliding of the seat with respect to the sub-frame
- 430/490mm frame height adjustable (only with 300mm and 500mm wheels)

The base frames are equipped with anti-tip wheels to reduce the risk of tipping.

The frame has also the following features:

- folding down backrest tubes
- detachable legrest tubes (where provided)
- quick-release posterior wheels:

This allows an easy transportation of the device during transfers.

The folding footplates/footboard (where provided), are adjustable in angle, depth, height.

The detachable knee angle can be:

- fixed 90°, 75°
- Elevating (with teathed mechanism).

Type of wheels

- posterior wheels:
  - 300mm (poly or pneumatic, or pneumatic with drum brake and lever)
  - 500mm (poly or pneumatic, or pneumatic with drum brake and lever)
  - 400mm (poly, or poly with drum brake)
- castors: 150mm/175mm poly

*Angles adjustments*

◆ **Tilting** (continuous with gas springs):

- from 2° to +35° (from 6° to 39°: tilt in space can be up-graded of 4° with an increment of the starting inclination of the frame by operating on the positioning holes of the casters forks)

◆ **Reclining** (by predetermined plates):

- 3°, 10°, 18°

### TECHNICAL FEATURES

Size	1	2	3	4	5	6	7
<b>Load (kg)</b>	30	30	50	50	50	50	50
<b>Frame weight (kg)</b>	12.6	12.8	13.4	13.6	14.1	14.5	15.1

Frame weight with wheels, knee angle and footrest as per standard configuration

Weight and overall dimensions of frame (mm) with folded tubes, legrests and posterior wheels detached							
Size	1	2	3	4	5	6	7
<b>Lenght</b>	640	660	640	660	660	680	680
<b>Width</b>	380	380	420	420	480	480	510
<b>Height</b>	640	640	650	650	660	660	670
<b>Weight (kg)</b>	9.4	9.6	10.1	10.3	10.7	11.1	11.5

**NOTE:** The overall dimensions in length, referred to average values, may vary due to adjustments. The values indicated are for the standard configuration.

Max Lenght (mm) with 75° angle	1	2	3	4	5	6	7
<b>300mm wheel</b>	860	890	860	890	890	920	920
<b>400mm wheel</b>	870	900	870	900	900	940	940
<b>500mm wheel</b>	910	940	910	940	940	970	970

**NOTE:** The overall dimensions in length, referred to average values, may vary due to plates displacement. The values indicated are for the standard configuration.

Width (mm)		1	2	3	4	5	6	7
<b>300mm wheel</b>	<b>standard</b>	430	430	480	480	530	530	560
	<b>with drum brake</b>	440	440	490	490	540	540	570
<b>400/500mm wheel</b>	<b>standard</b>	450	450	500	500	550	550	580
	<b>with drum brake</b>	480	480	530	530	580	580	610
<b>Pivot width (mm)</b>		660	660	690	690	720	720	750
<b>Q (min-max) height from the seat tube to the footrest (mm)*</b>		130-200	130-200	130-230	130-230	130-230	130-260	130-260
<b>H Seat tube height (mm)**</b>		430 e 490 with posterior wheels 300/500 and anterior 150/175 450 with posterior wheels 400 and anterior 150/175						
<b>Max slope</b>		7°						

**NOTE:** \* The value Q, referred to the hanger at 90° can be increased of 5-7 cm. with the use of the hanger at 75°

\*\*The value H is taken outside to outside seat tube at the tilt in space plate; the frame will be delivered with H=43cm for 300/500mm wheels